

THIS DRAWING IS UNPUBLISHED. RELEASED FOR PUBLICATION
 © COPYRIGHT BY TYCO ELECTRONICS CORPORATION. ALL RIGHTS RESERVED.

LOC		DIST		REVISIONS			
P	LTR	DESCRIPTION		DATE	DWN	APVD	
FT	0	V		REVISED PER 0G3B-0466-03	7/14/03	SS	SH

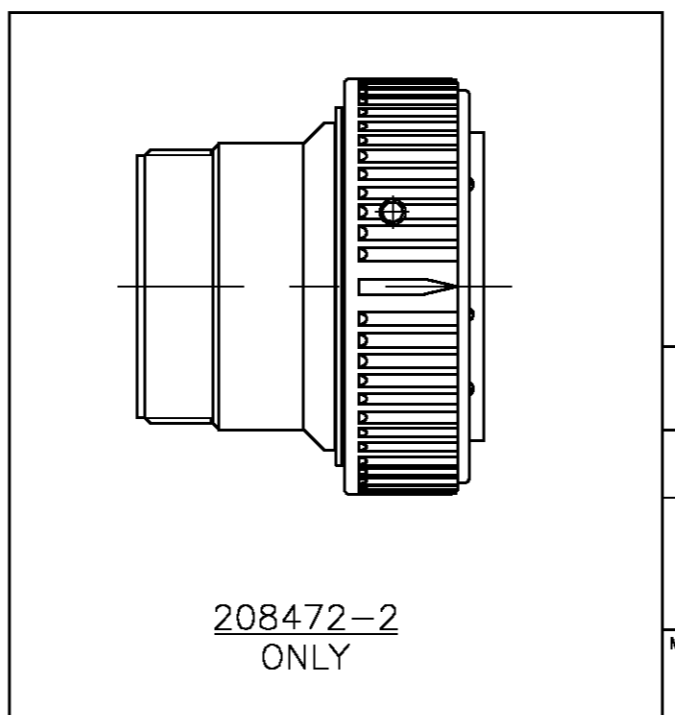
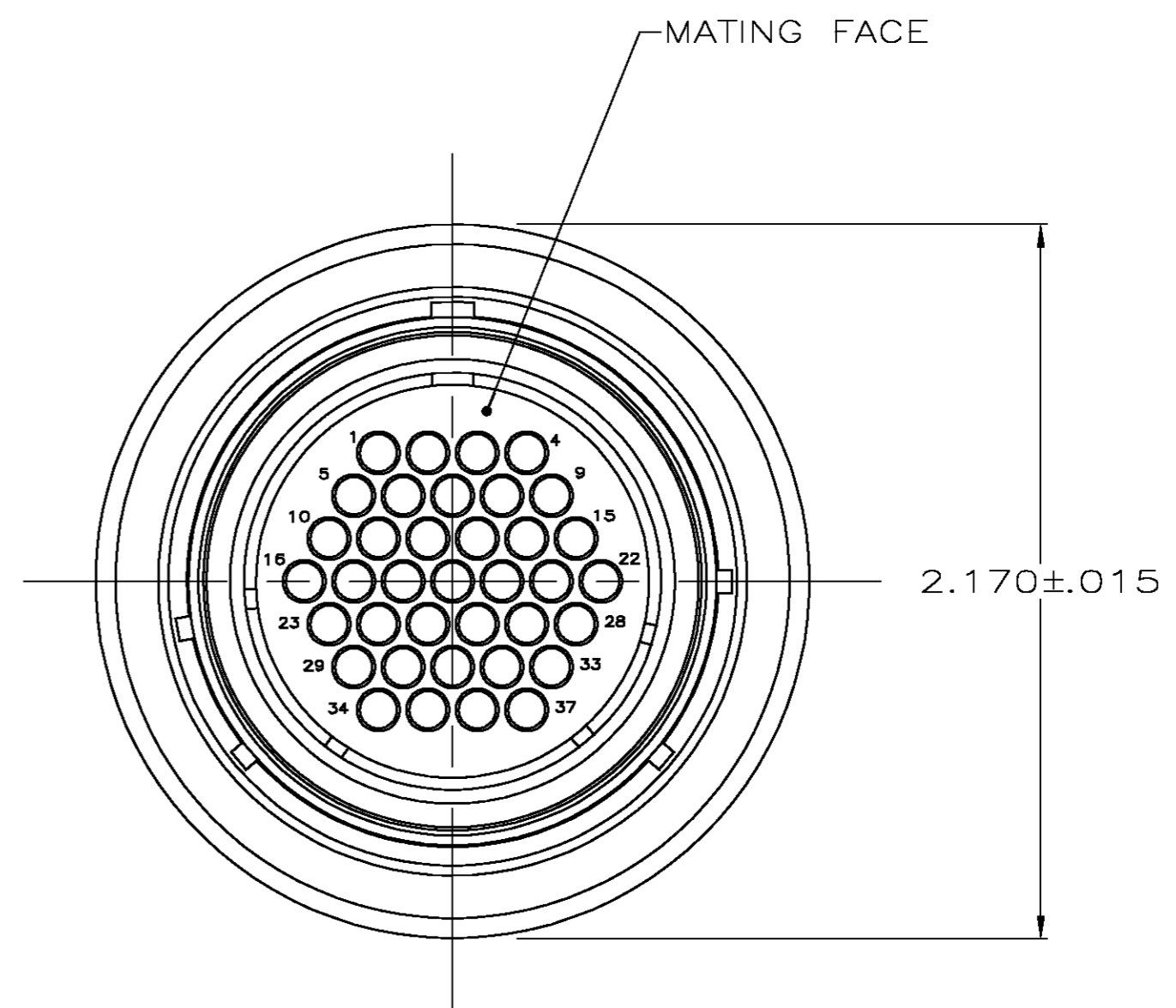
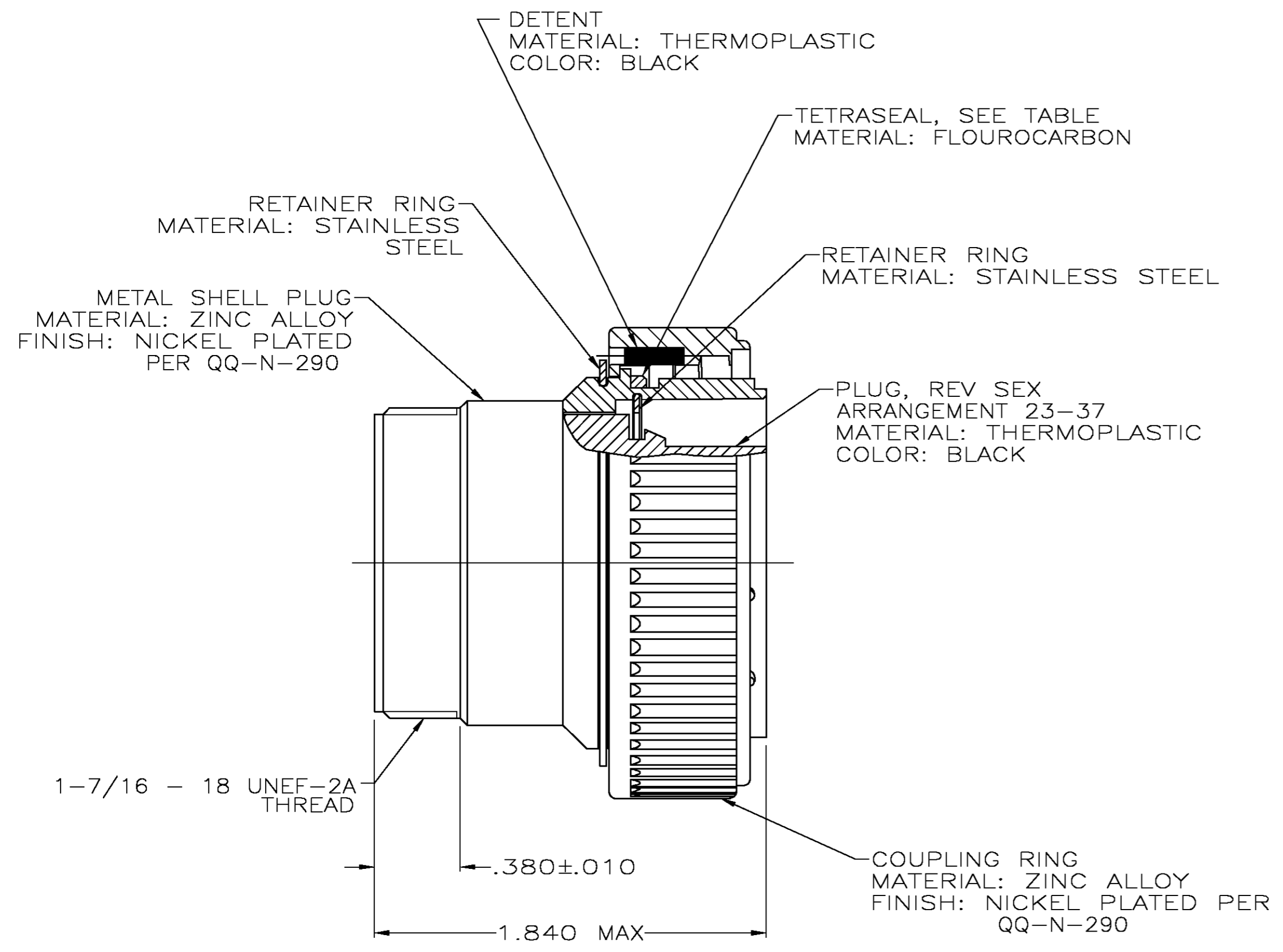

1. AMP PART NUMBER AND DATE CODE TO BE LOCATED ON COUPLING RING.

NO	YES	208472-3
YES	YES	208472-2
NO	NO	208472-1
SECONDARY LOCKING FEATURE	TETRASEAL	PART NUMBER

THIS DRAWING IS A CONTROLLED DOCUMENT.		DWN R.LEE BG 6-25-91	Tyco Electronics Corporation	
DIMENSIONS: INCHES		CHK W.G.LENKER 4-16-92	Harrisburg, PA 17105	
TOLERANCES UNLESS OTHERWISE SPECIFIED:		APVD -	NAME	
0 PLC ± -	1 PLC ± -	PRODUCT SPEC 108-10040	PLUG ASSEMBLY, REV SEX, SERIES 1, 28-37, CMC	
2 PLC ± -	3 PLC ± -	APPLICATION SPEC -	SIZE A2	CAGE CODE 00779
4 PLC ± -	ANGLES ± -	WEIGHT -	DRAWING NO C=208472	RESTRICTED TO -
MATERIAL SEE CALLOUT	FINISH SEE CALLOUT	CUSTOMER DRAWING	SCALE 2:1	SHEET 1 OF 1
			REV V	